

BT Merlin

>Office Automation?

There's so much to choose from

~where on earth do I start?<

>Everything's changing so fast

~would I do better to wait?<

>I know we need help with

admin~but would automation

just bring new difficulties?<

Our answer: Merlin Systems

The combination of advanced computing, sophisticated electronic communications and easy operation makes a Merlin system the finest available way to automate your office.

Merlin is flexible

Your company is unique, with a unique mix of needs.

The Merlin range has been designed from the start for maximum flexibility.

You buy only the precise equipment and programs you need now. Then, as you grow, the system can be enhanced in a variety of ways.

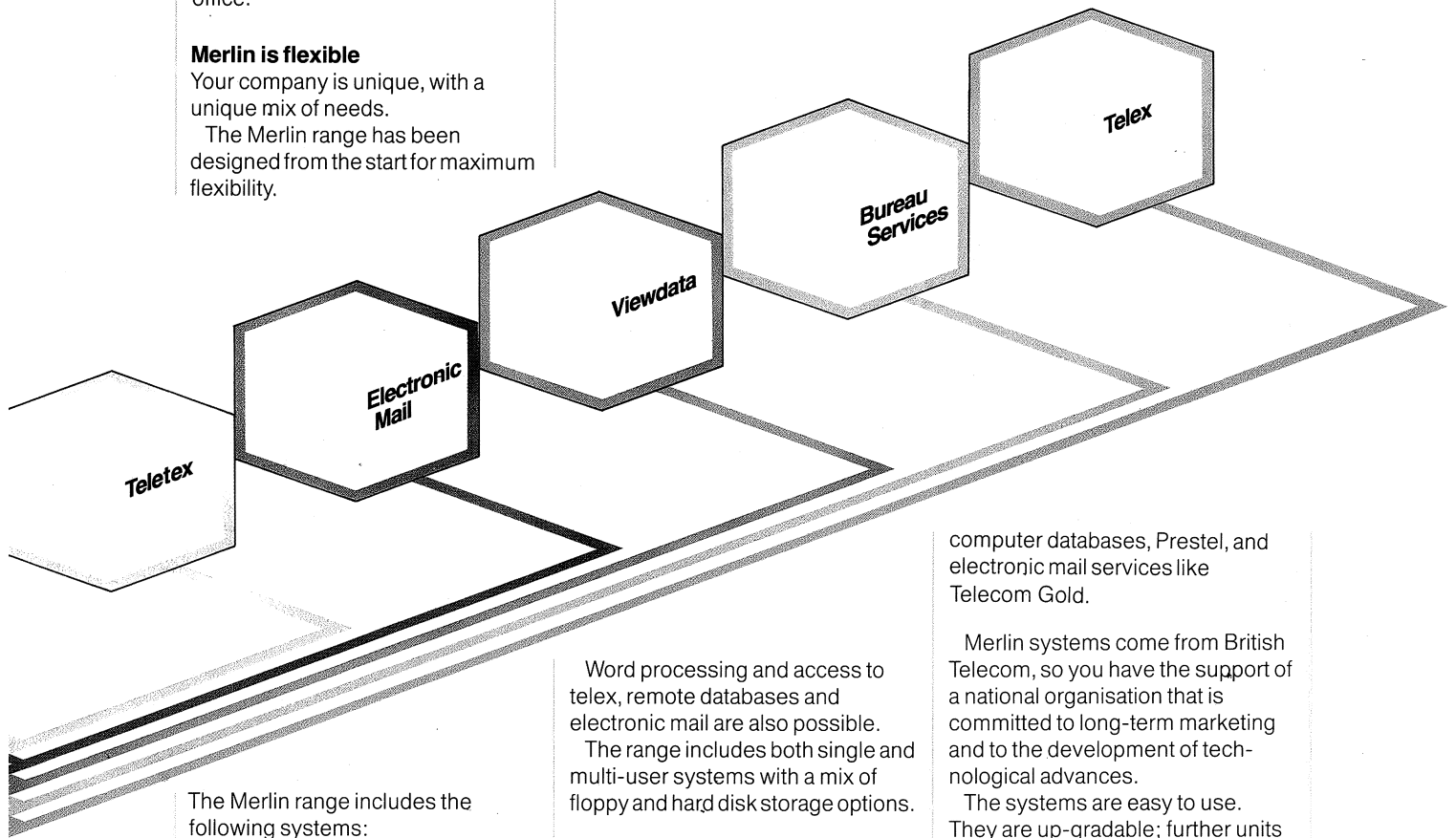

The Merlin range includes the following systems:

The M1100 data terminal

A remote access device for computer bureau service users which also provides communication with many business information and data storage services, and with electronic mail.

Press one button and the M1100 automatically connects you with the service you have chosen.

The M2200 range of small business computers

These powerful computers can handle a wide range of office administrative functions, thanks to a choice of well-tried applications programs. They also incorporate the unique MerlinMaster on-screen user guidance system for easy step-by-step operation.

Word processing and access to telex, remote databases and electronic mail are also possible.

The range includes both single and multi-user systems with a mix of floppy and hard disk storage options.

The M3300 word processor

Powerful flexible word processing plus the very latest electronic communications make the M3300 an exceptionally useful machine.

Via the Puma teleprinter, it can connect with the world Telex network, sending text without re-typing. It can also send to and receive information from remote

computer databases, Prestel, and electronic mail services like Telecom Gold.

Merlin systems come from British Telecom, so you have the support of a national organisation that is committed to long-term marketing and to the development of technological advances.

The systems are easy to use. They are up-gradable; further units can be added whenever necessary.

From one organisation you can have equipment, software, training, maintenance, consumables and accessories as well as all the help you need to get your system working.

In the bewildering and risky world of office automation, you can be sure of one thing: You're safe with Merlin, the British answer that's right for today and here to stay for the future.

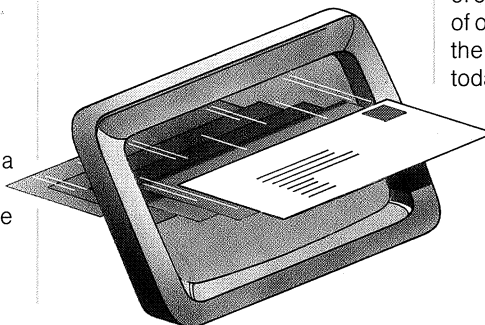

Your questions about office automation

You probably have a shrewd suspicion that automation could improve the efficiency and productivity of your office.

But you certainly have a headful of questions to prevent you taking any action.

– There's a bewildering variety of equipment on the market. How can you find your way through to the right answer for your company?

– Everything is changing so quickly. How can you be sure that anything you buy will not go out of date, wasting your investment?

– Do you need a dedicated word processor? Or a micro computer with word processing facilities?

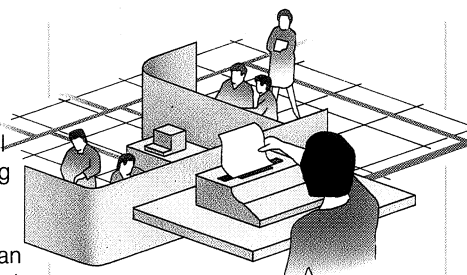

– How can you install your system without disrupting everything and everyone?

– How you can find real guidance and practical help with application software selection, finance, training, and servicing?

For all sized businesses, lacking technical staff, these are real questions. But now Merlin provides real answers. And real, practical, money-spinning benefits.

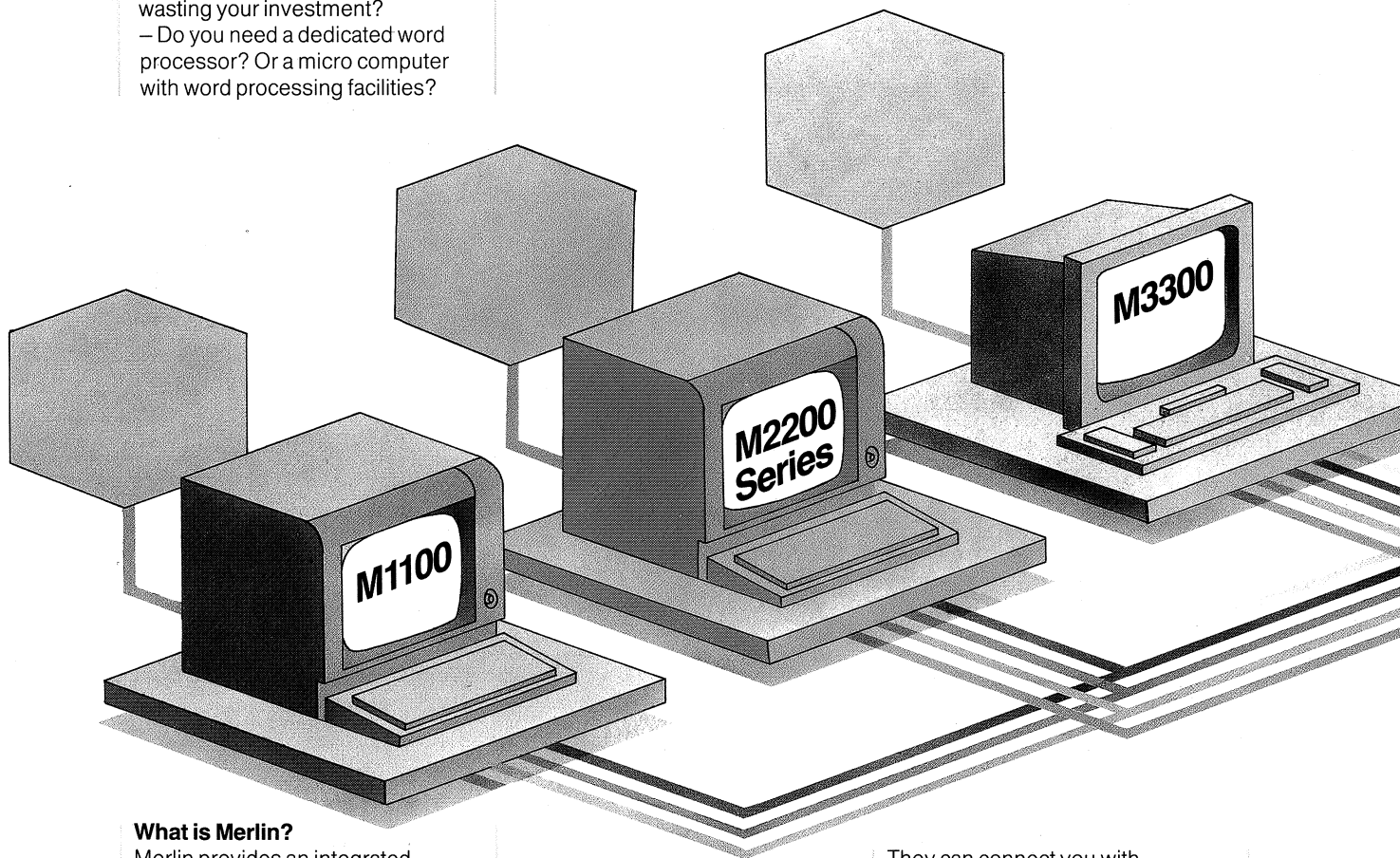

What is Merlin?

Merlin provides an integrated, complete and properly planned range of systems and programs for automating the offices of large, medium and small businesses. All systems have been tried and proved in practice. They are outstandingly easy to use and excellent training is provided to ensure maximum advantage is taken of their capabilities.

What can Merlin do?

Merlin computer systems can streamline many routine office functions such as information storage and retrieval, accounting, payroll, ledgers, mailings and financial planning with immense savings in time and improvements in accuracy and flexibility.

They can connect you with computer bureaux, databases, remote computers, Prestel, and electronic mail, which gives access to an invaluable range of information, and to time-saving new communications services.

There is a powerful word-processing and text editing system, coupled with automatic electronic communications, to save both secretarial time and eliminate postal delays.

Greater efficiency. Higher productivity. Cost-effective investment. Simple operation. These are the main benefits of Merlin Office Automation.

Here at last is an integrated range of systems for all sized companies. They present powerful computing and advanced communications in ways tailor-made for busy, hard-working people.

Merlin systems. The practical, simple, powerful way to automate your office.



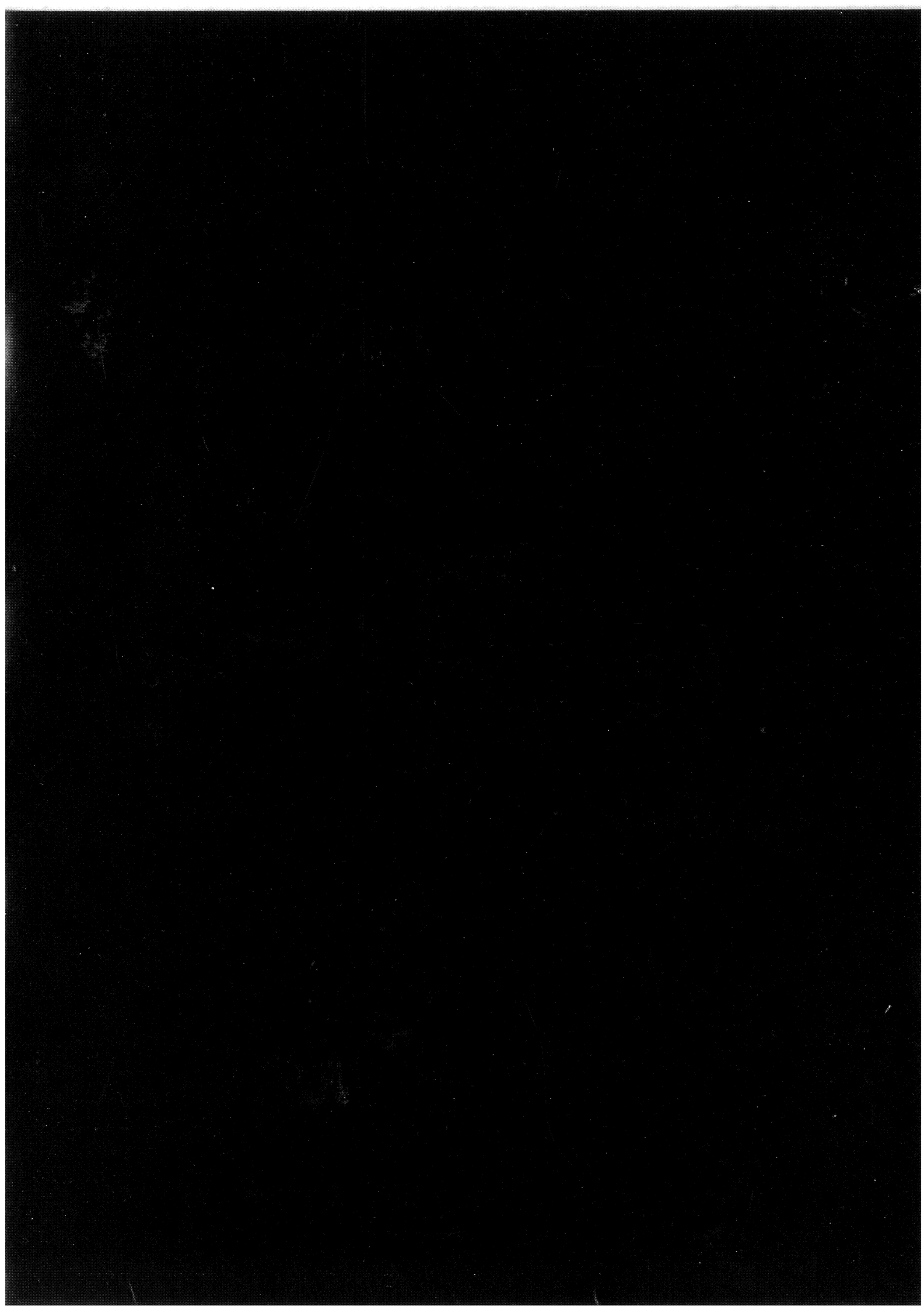

Behind Merlin – the strength of British Telecom.

Merlin is the specialist organisation set up by British Telecom to develop and market advanced terminal equipment for businesses.

It is backed by the full strength of British Telecom resources and expertise.

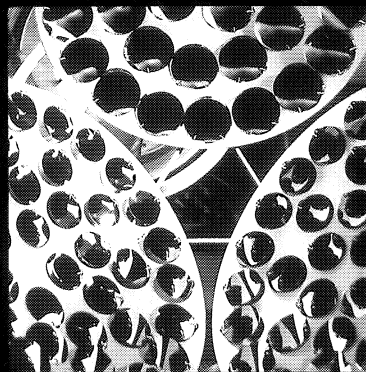
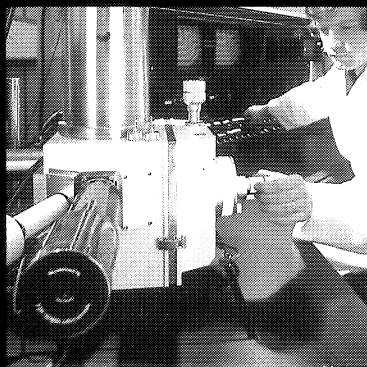

We enjoy an enviable reputation as a sound, reliable supplier of communications equipment. We supply systems which have been tested and proven in stringent market conditions. Reliability, and ease of use are hallmarks of the Merlin range.



Merlin

British Telecom Business Systems

Merlin M3300

The word processor that's also a complete business system

The benefits of word processing

When you use a typewriter, you print your text directly down onto paper.

When you use a word processor, you type your text into a computer memory. It is simultaneously displayed on a VDU screen.

Once the text is in the memory, it can be corrected, changed and laid out in different ways. Paragraphs

can be deleted and moved around. Words can be altered, and the computer automatically moves the rest of the text and adjusts the pagination to compensate. Once correct, the text can be

printed out automatically or permanently stored on disk or communicated electronically to other terminal devices.

All this spells the end of repetitive typing, enables speedy revisions of texts and documents, and achieves massive savings in time and improvements in productivity and document quality.

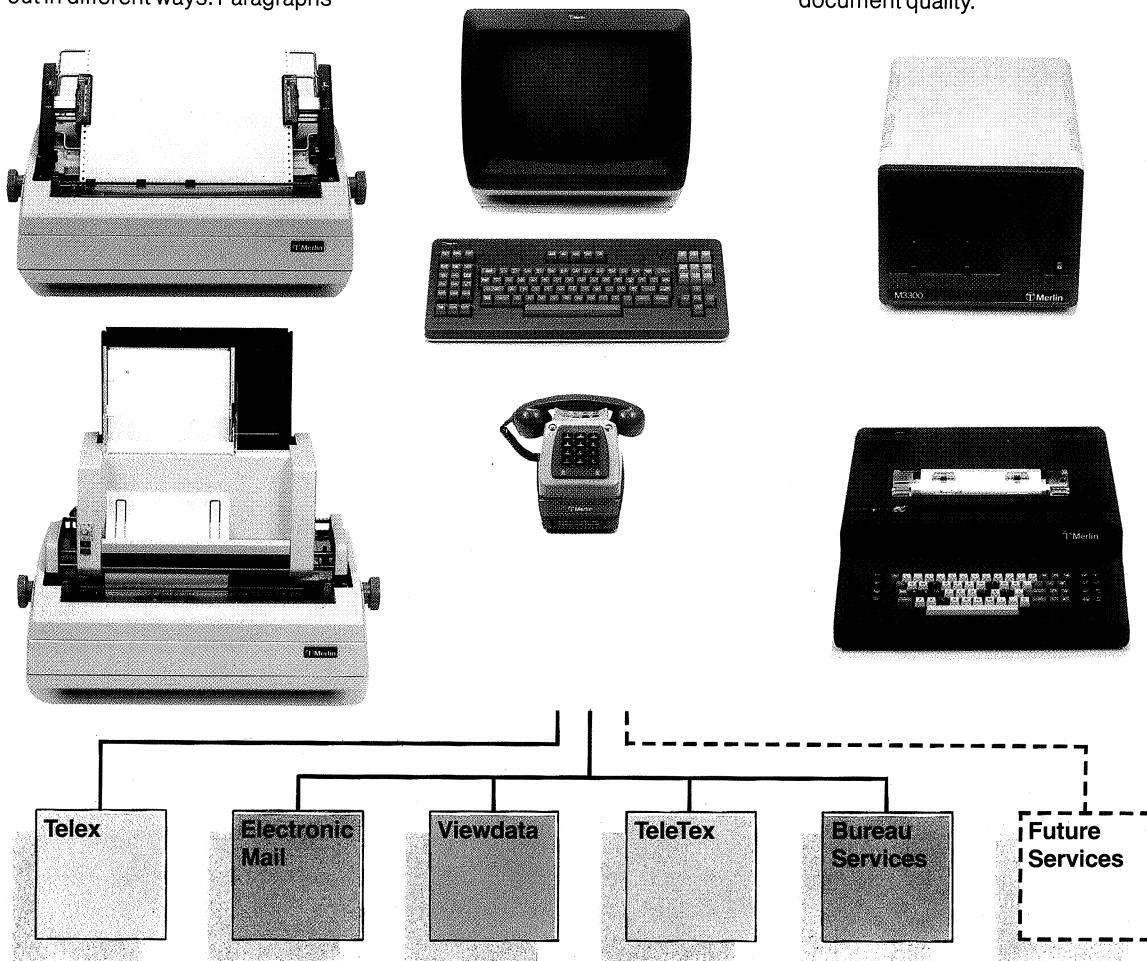

Questions to ask before buying a word processor

The market offers a bewildering choice of word processors. By asking a few simple questions, you can avoid the dead wood and get quickly to the right answer.

Will the system communicate?

Will it let me transmit text by Telex? Can it connect with Prestel, with computer bureaux, with remote databases, with electronic mail services?

Can I be sure my staff will take to it quickly and use it fully?

Does it have a familiar, typewriter-style keyboard? Will it instruct the user with simple, plain English instructions? Will it solve problems rather than creating them?

The answer: Merlin M3300

The Merlin M3300 can answer yes to all these questions. It is a powerful, dedicated word processor which is remarkably simple and comfortable to use. It can perform the full range of word processing tasks and also offers three important communications options.

The M3300 thus provides the latest word processing and communications facilities in a hard-working, reliable and easily mastered machine.

The Merlin total back-up

The M3300 is backed by a complete range of services

All Merlin products are supported nationally providing the services and help you need.

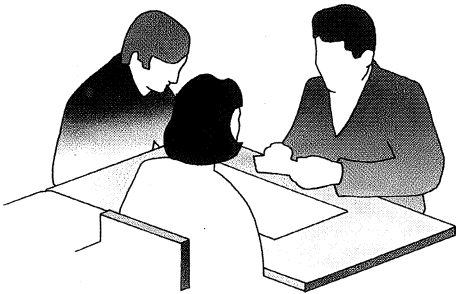

Installation. We deliver your M3300, of course. But we don't leave it at that. We install and start up the system, and make sure that it is performing flawlessly to your—and our—satisfaction.

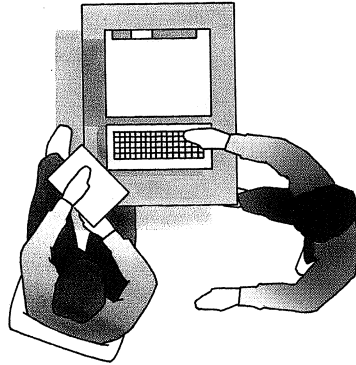

Training. Considering the sophistication of the M3300, it is remarkably easy and quick for non-specialist staff to learn to use it. A short training course is all that is required. This is provided at our local training centre or at your own offices.

Planning and finance. We can help plan your system to meet your requirements. Once the installation you need has been defined and costed, we can provide help with acquisition through our leasing plan.

Service and maintenance. Our national after-sales and maintenance service exists to keep your equipment in first-class order. Difficulties can be dealt with through our telephone hotline service, which provides immediate guidance and problem-solving. Should break-downs occur, call-out engineers will quickly put things right again.

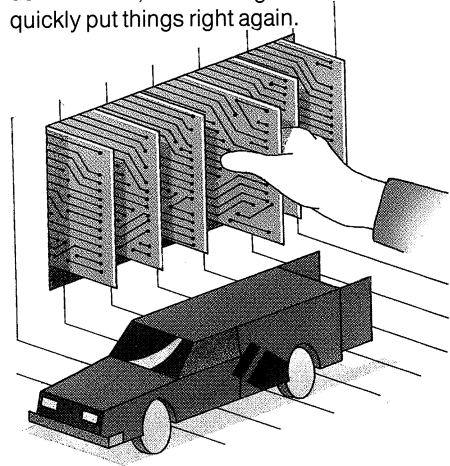

Behind Merlin—the strength of British Telecom

Merlin is the specialist organisation set up by British Telecom to develop and market advanced terminal equipment for businesses. It is backed by the full strength of British Telecom resources and expertise. Over the years, British Telecom has established itself as a leader in the field of telecommunications

hardware and networks, and can fairly claim to be the only Office Automation supplier that really understands the new communications technologies.

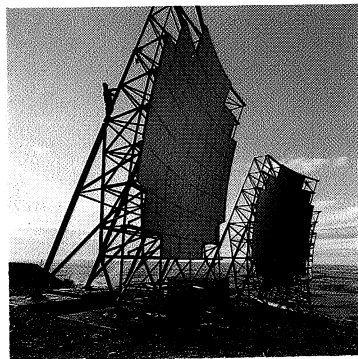

We enjoy an enviable reputation as a sound, reliable supplier of communications equipment. We supply items which have been tested and proven in stringent market conditions. Reliability, and ease of use are hallmarks of the Merlin range.

The power to communicate

Hitherto, word processing and communication have been treated as separate technologies. But real office automation demands convergence of the two—a concept central to Merlin. So the M3300 can communicate electronically through three optional add-on devices.

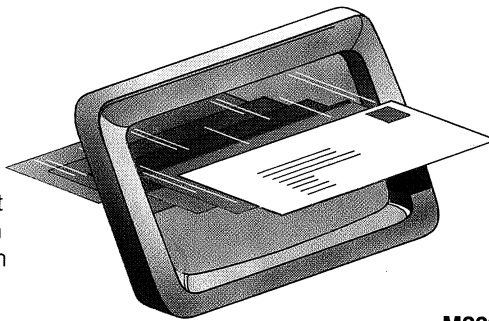

The Puma teleprinter enables the M3300 to transmit and receive Telex messages. Anything stored on disk or in the memory can be transmitted without retyping. Multiple M3300 units can be clustered on one Puma teleprinter.

MerlinTex connects the M3300 to all users of teletex—the international text and data communications service. This uses the telephone network to provide fast electronic communications.

M3300 grows with your company

To keep your initial investment as low as possible, you can start with the basic M3300 unit which consists of keyboard, VDU, control unit and printer. Later, you can upgrade the facility by adding on communications modules, a Puma teleprinter or additional M3300 units.

Full flexibility is thus assured and your initial investment protected.

The Modem Option connects the M3300 with computer bureaux, timesharing computers, Prestel, electronic mail services and other databases.

A small switch allows both Telex and Modem Options to be installed.

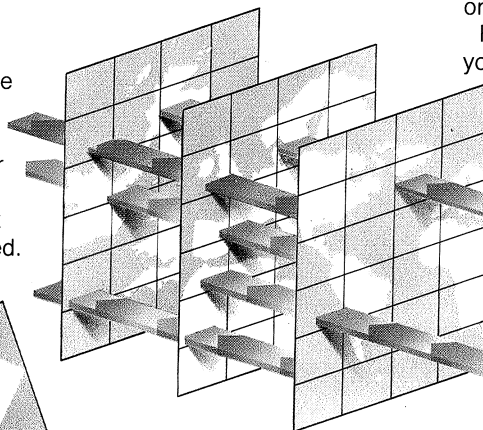

Only a word processor?

No! Just add the operating system known as CP/M-86* to your M3300 and it is transformed into an extremely powerful 16 bit computer. Two in one—and it's much cheaper than buying another computer!

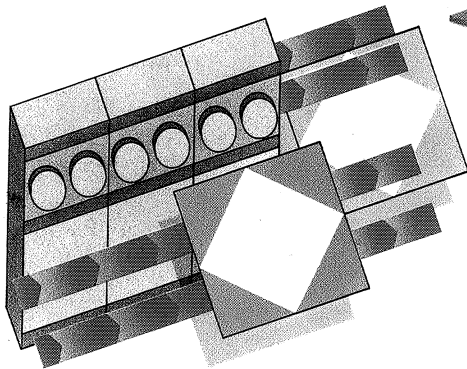

The automatic send and receive facility can transmit text or data unattended—even during the night. Because communication is electronic, memory-to-memory, an A4 page can be sent or received in about 25 seconds, with enormous savings in phone costs and even postal charges.

*A registered trademark of Digital Research Inc.

Making friends is easy

The M3300 looks friendly and inviting. It's elegantly styled. The screen is adjustable for brightness and angle. The ergonomically-designed keyboard uses the familiar 'Qwerty' layout. Instruction keys carry simple words, not obscure symbols.

Yet this easy-going exterior contains formidable processing power. It can handle most of the major West European languages; and that includes American. It can also handle up to 240 A4 pages at a time, which can be subjected to a complete range of word processing operations:

A complete range of WP abilities

Text editing. Words can be changed, emboldened, under-scored. Superscripts and subscripts introduced. Sentences altered and deleted; lines centred or positioned in columns of any width; paragraphs added, removed or moved around; mistakes corrected. It's all done instantly on the screen, and then a perfect copy printed out. Retyping time is cut by up to 60%.

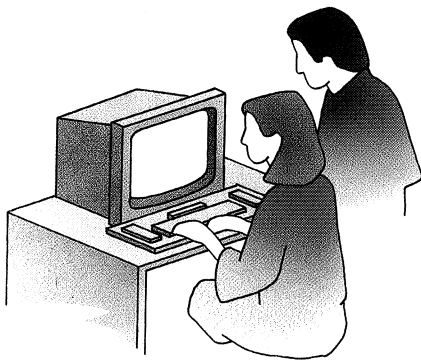

Search and replace. If a document contains a much repeated word or phrase that you want to change, the M3300 will run through the entire text locating it, replacing it or deleting it. The rest of the text is of course moved back or along to retain correct spacing and the pagination is automatically adjusted. Without having to chase through an entire report, it will when you want, go directly to the page you choose.

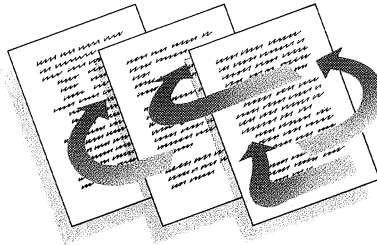

Automatic merging and repositioning of text. Paragraphs from different disks can be automatically merged and positioned to give a flawless finished document.

Retrieval of records and lists.

The M3300 can act as an electronic filing and mailing list system, retrieving and printing out stored records and lists automatically, at the touch of a button.

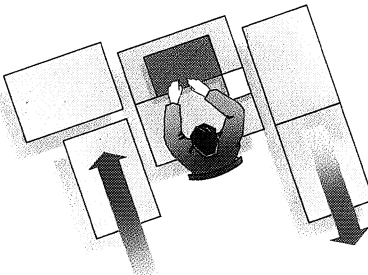

Automatic pagination. Pages can be laid out and numbered automatically as the text is printed out.

Form handling. The M3300 can create form layouts and text, storing the entire form in its memory for immediate retrieval, and for automatic positioning of text on the form.

Top-quality print. The daisy wheel printer offers a range of typefaces and pitches. It operates at 700 words per minute, creating crisp, flawlessly typed documents. And if you want diagrams made up of vertical and horizontal lines, it will produce those crisply, flawlessly as well.

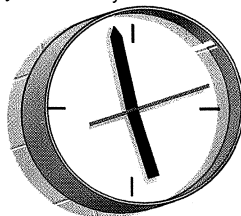

An infinity of layouts. Margin spacing, layout, rules, columns, even newspaper pages can be laid out automatically to your instructions. Once the format is established, you just put in the words and numbers for completely automatic creation of a flawless finished result.

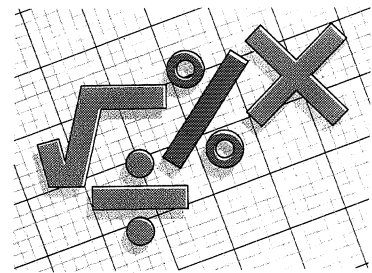

Calculations. The microprocessor at the heart of the M3300 can carry out addition of rows and columns of figures, subtraction, multiplication, division and percentage calculation when required.

Personalised correspondence.

Letters can be typed to a standard text, with the facility to type in names, addresses—or to draw them automatically from stored lists. Varied paragraphs can be inserted, or personalised paragraphs put in.

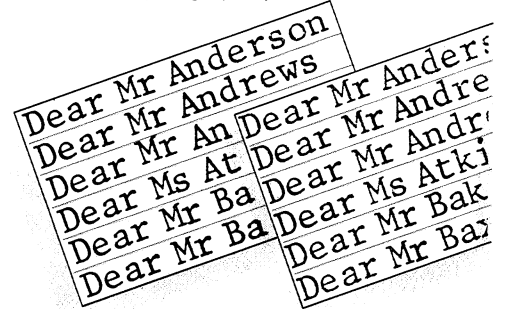

Unlimited storage. Each 5 1/4" disk stores up to 120 A4 pages. Insert the disk, press a button and the stored information is immediately presented on the VDU, ready for processing.

M3300

Hardware

Processor	8086
Memory capacity	256K
Data storage	268K per disk; two 5¼in floppy disk drives; uses double-sided double-density disks
Disk drive/processor dimensions	width 330mm; depth 500mm; height 250mm
Screen size	15in diagonal displaying 24 x 80 characters
Screen colour	gold characters on bronze; LA phosphor
VDU dimensions	width 350mm; depth 500mm; height 350mm
VDU weight	12.7kg
Keyboard type	detachable; QWERTY layout
Keyboard dimensions	width 480mm; depth 200mm; height 80mm
Keyboard weight	2.4kg
Printer interface	parallel

Daisywheel Printer

Printing speed	60 characters/sec, bi-directional
Line feed speed	4in/sec, bi-directional
Carriage return speed	.3 sec/13.6in
Tabulation speed	.3 sec/13.6in
Letterspace resolution	±.008in
Line feed resolution	±.021in
Max characters per line	ten pitch, 136; twelve pitch, 163; fifteen pitch, 204
Max paper width	380mm
Max number of copies	original plus six
Daisywheel	124 characters, dual plastic, range of interchangeable typefaces and pitch available
Print ribbon cassettes	black film or black fabric
Noise level	67dBA
Dimensions	width 625mm; depth 355mm; height 200mm
Weight	22kg

M3300 Modem

300/300 bits/sec asynchronous full duplex transmission with integral push button telephone with repertory dialling facility

Merlin is British Telecom's specialist marketing organisation for advanced business terminal equipment.

If you would like further information on these or any other Merlin products, please dial 100 and ask for FREEFONE MERLIN. The operator will put you through to your nearest Merlin sales office, where our staff are ready to discuss your needs.

The products described in this brochure are available only from British Telecom Merlin.



Merlin

British Telecom Business Systems

Please note: we do our best to supply our customers with the apparatus they ask for but we may have to provide apparatus which does not accord exactly with the descriptions, illustrations and shades of colours shown in this leaflet.

APPROVED for use
with telecommunication systems
run by British Telecommunications
in accordance with the conditions
in the instructions for use.

Merlin M2200 Series

The right computer for your business

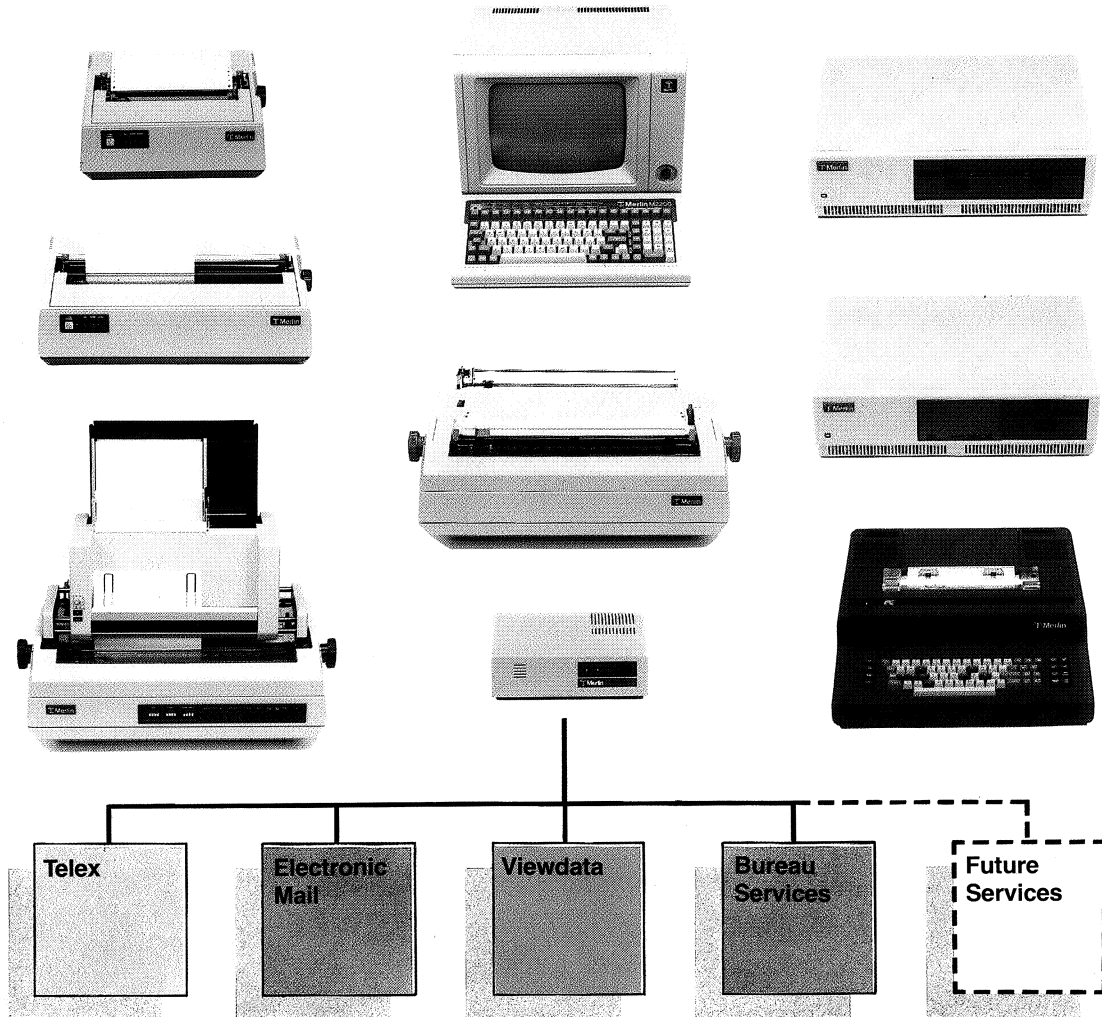

The M2200 range of micro computers has been specifically designed for businesses. They will make a secretary's work easier and make her more efficient. They will help managers to plan and can streamline many day to day office functions. They have no unnecessary frills and only the right programs that have been created to serve business.

But, more than any ordinary computer, they give businesses access to a complete communications package, by way of the telecommunications networks.

They can provide information from almost any source to the right person at the right time; whether it be from outside or inside your company.

Above all, they provide businesses with the opportunity to become more efficient, to react faster and to work more profitably.

There are three systems in the M2200 range: The M2215 which is a single-user, dual floppy disk system. The M2226 which is a single or multi-user system with a hard disk

and a floppy disk drive. The M2235 which is similar to the M2226 but has a greater capacity hard disk. The system you choose will depend mainly on the jobs you want it to do, the power you need and the number of users requiring access to it.

Depending on its type, every system can support a combination of screens, keyboards, printers and modems and has the ability to connect with a Puma teleprinter.

The right help for all businesses

The right computer can make a very considerable difference to your company. It can do all those routine, time-consuming jobs that people find so dull and un-inspiring.

At the same time it can help you to plan ahead. It can produce accurate cash projections in seconds. It can help you make forecasts and analyse data. The right computer can

even make 'what if' suppositions for you.

With the right hardware and software, there is no doubt that your company can be made to run more efficiently and competitively.

However, while you will certainly have been told about the advantages, you will also probably have heard of some of the problems.

It is worth taking a shrewd look at these problems since they are easy to avoid. In almost every case, they stem from choosing a computer which simply doesn't meet your pre-determined needs.

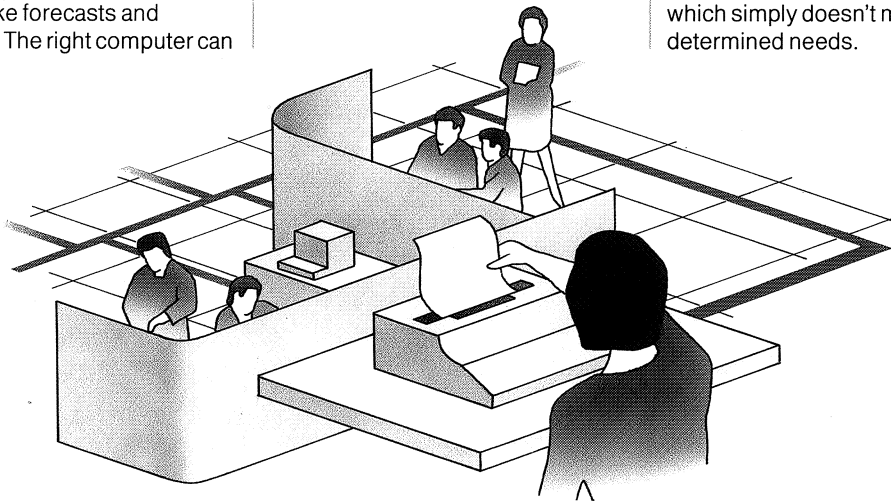

Will my business outgrow my computer?

You expect your computer to help you to grow. But, when it has done this, will it prove inflexible; capable of only one job? If, for example, you have decided to computerise your payroll, will your computer turn out to be incapable of making sales forecasts?

How long will it take?

This is a very common complaint. A company installs a computer hoping to boost efficiency, only to find itself bogged down in teething problems, training problems and systems problems. So that six months after spending the money, the job is still being done the old way!

Narrow minded.

There is no doubt that some systems are very limiting. They only provide you with a very small range of 'ready made' programs and, if you want to use other programs, they can't accept them.

After Sales Service.

You want to make sure not only that the system is capable of growing with you, but that the organisation that sold it to you will continue growing. Will its research programmes produce new products and programs that will keep your equipment up to the minute? And, above all, does it have a history in the micro-chip industry?

Adaptability.

Your computer ought to be the focal point of all your office automation. Yet far too many users find that it becomes used only for one function by one department. If the computer has the right capability it can help in almost every area of your business.

Can it communicate?

Of course a computer will communicate with its owner. But that's not using its full potential. A computer ought to be able to use the public telecommunications networks for data communications and text exchange. With Merlin's auto dialling modems and teleprinters, the layman can do this simply without needing to be a data communications expert.

Finding the answers

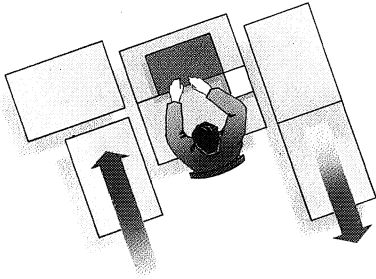

Fast-growing technology.

The secret of being able to use the best of the latest technology is to have a system built to international standards. Then, when a new idea or service becomes available, you can buy it, certain that it will match your existing system. Your original investment is protected by the introduction of new software which continuously extends the ability of your computer to solve problems.

As you will probably have heard, the technology available isn't only within the confines of your system. External communications are vital and the M2200 has the added advantage of giving you access to electronic mail services: you can send and receive data and messages using an electronic 'mail box'.

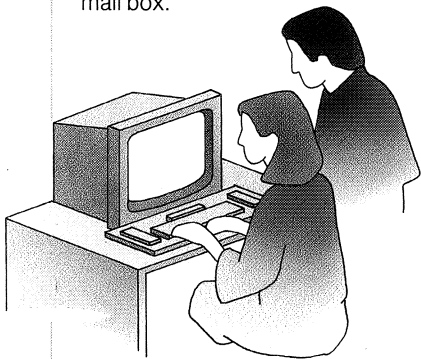

User Friendly.

The days when a computer could only be used by an extensively trained operator are over. The M2200 is one of a new breed of computers which speak plain English not computer jargon.

Therefore teaching someone to use the full range of programs available will take a few days, not weeks. And, in most cases, the instructions given by the machine will be completely self-explanatory, so that even first-time users will get the answers they want.

The best programs.

The M2200 has a comprehensive range of programs designed to cover pretty well everything that a business might need. But, more than that, it can accept any other CP/M program. Like any properly trained machine, it will do what you want it to do.



The reason for this is a program called Merlin Master, which provides you with a very simple 'menu' of choices. Rather than having to spend hours searching through computer manuals, it tells you, at once, in plain English, what choices you have got and what you have to do to exercise these options.

The service you need.

Reliability is vital and service is what counts. We can arrange a four-hour service (Express call-out) or a 24-hour service (Standard call out).

Not that you are likely to use this service often. We run the largest research programme in Europe so we have ironed out most of the possible wrinkles. And, if you have any questions, rather than problems, we are running a customer 'hot line' for your enquiries.

Total communications system.

When talking to businessmen about just what they want from a computer, the most common request was for a 'complete system'.

A machine that would perform all the functions necessary for the smooth running of a business and, at the same time, communicate information, gather it and distribute it to the people who matter.

The series M2200 can do exactly that.

For a start it can become a word processor: type what you want on to the machine, correct it, alter paragraphs, change the order and when you're ready, have it printed; automatically. And, with a computer's memory, you can naturally have the same letter or many variations sent to all your sales prospects; all personalised, of course..

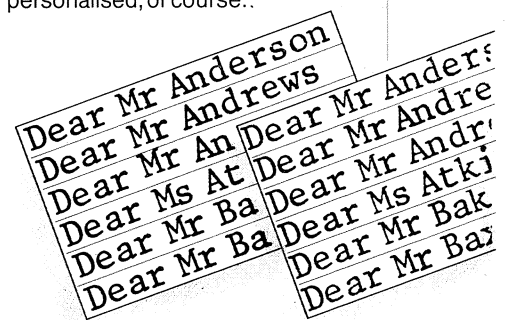

And, to make sure that all your communications are spelled correctly, it has a 'memory' of the correct spelling of 20,000 words!

The same machine will then work out your sales forecasts, check your figures, work out the company's payroll and file information.

It can then give you access to external services such as Prestel and other private Viewdata services. Or it will communicate with other computers around the country, receiving the information you need. It can use it for a new basis for data and calculations and then transmit that information by way of a telex, or electronic mail to any other office.

All the right programs for your business

A computer is a brilliant piece of electronics, but without the right programs, it is just so many pieces of silicon. Getting the right programs for your business is almost as important as getting the right computer. Which is why the M2200 is provided with a diverse and continually developing range of specifically designed business programs.

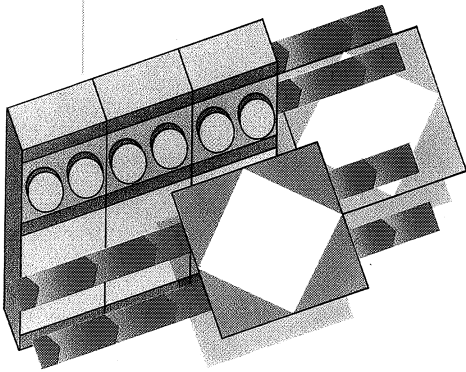

They turn it into one of the most sophisticated business tools you can buy. Because, as well as being able to undertake exceptionally advanced business projects for you, the M2200 is also a centre for both gathering and sending information to and from your clients, suppliers, subsidiaries and business prospects.

It is, in fact, a complete business communications centre.

People do it better

At the heart of every business are invoicing, sales, stock control and purchase ledgers. The M2200 has a program which takes care of these for you, keeping them up to the minute and saving you hours of time which you could be spending more profitably by managing,

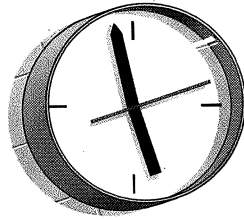

directing, thinking; all those things, in fact which people can still do so much better than machines.

This is the point of the whole M2200 system. To take the drudgery out of business, and do all the repetitious, time consuming and therefore expensive jobs that people find so un-inspiring.

At the touch of a button

With it you will be able to make financial projections. Not just simple sales forecasts, but complex 'what if?' business plans. You will be able to have your payroll done automatically, every week or month, by cheque, cash or credit transfer. You'll be able to keep a firm grasp on all your records and files. Information available at the touch of a button!

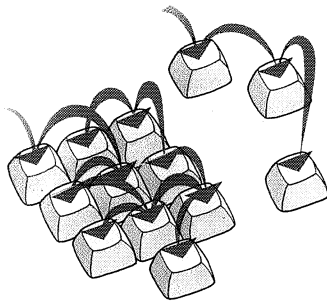

The future

Once you have installed the system and arranged it to do just what you want, that's not the end of it.

This is, as everyone will tell you, a world that's changing faster than ever before. New programs will be introduced by Merlin all the time. Each one will be in plain English. Each one will be easy to use; we don't ever want to try and blind you with science or sell you a program that isn't 100% useful. We never make innovations for the sake of innovation.

MerlinMaster

This program, which is the basic key to the system, will give you some idea of how simple the M2200 is to operate.

It turns your computer into a friendly, useful machine right away. First it shows you a menu of your options; you need no training to understand that. Then it explains, in plain English, exactly how to operate the machine to get what you want. Also in plain English. And the operations are as simple as the instruction.

It will automatically call up Prestel information for you, the Telecom Gold electronic mail box service, Packet SwitchStream or computer bureaux. In addition it will take documents from your computer and transfer them automatically to the Puma teleprinter for transmission over the telex network. Or will receive telexes direct from the Puma teleprinter.

Total communications package

More than simply providing you with systems that help you run your business, the M2200 helps you communicate. Connect up to the telephone network with a modem, and you can process, transmit and receive data.

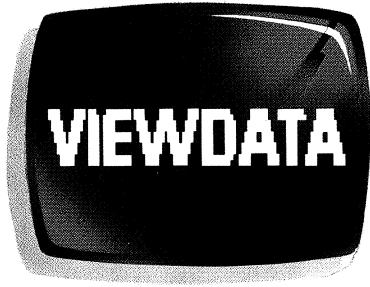

Prestel

When you need information, all the best services are open to you. Your modem will store all the access numbers you need to dial up and log on to Prestel or other Viewdata systems. Or you can dial up private data bases, all at the press of a button.

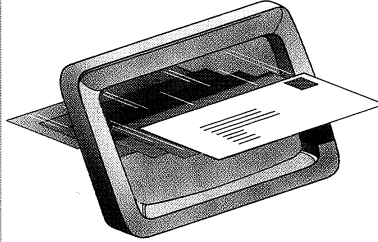

Electronic Mail

You can send and receive messages, using an electronic 'mail box', through your computer system. Computer talks to computer through such services as Telecom Gold.

Telex

You can send a message direct to the Puma teleprinter. It will store and transmit at the time you choose. In the same way, a message can be received by the Puma and then passed to your computer when you are ready.

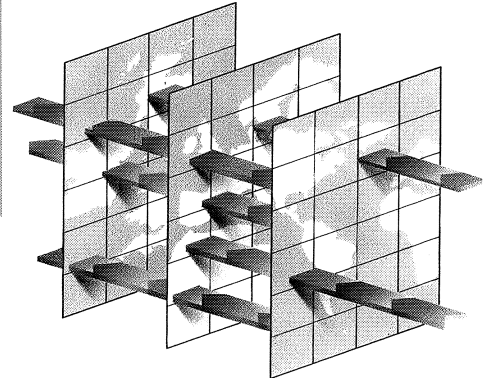

The Merlin total back-up

Every wise businessman will recognise the importance of service on a machine such as this, once it is installed and running. Which is why we have placed such emphasis on service, from start to finish, from pre-sales to after-sales.

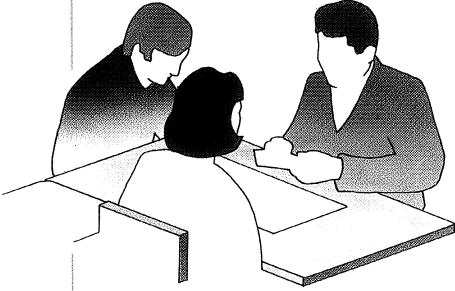

Before you buy

Deciding exactly what you want your computer to do is rather a 'chicken and egg' business. Before you can decide what you want it to do, you need to know what it is capable of doing. Therefore we can help and advise you which system is best suited to your company and which packages you need to help you.

Installation

We deliver your computer, of course. But we don't leave it there. We install and start up the system, and make sure that it is performing flawlessly to your—and our—satisfaction.

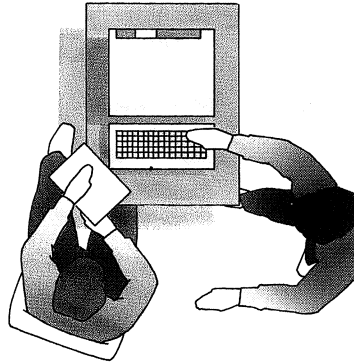

Training

We can arrange to train the people you want trained either at your office or at our training centre. And we can give you and your managers an intensive appreciation course so that everyone rapidly realises the potential of the system.

After sales service

As well as our 'product hotline' which is free to customers who want to enquire about their systems, we offer three options for maintenance:

1. Standard Call Out. A 24-hour response arranged by contract.
2. Express Call Out. A 4-hour response also arranged by contract.
3. A service counter where customers can come for repairs charged on a job by job basis.

However, you will need advice when you want your system to grow. When you decide which extra facilities you need, we can help. And, as all our equipment is compatible, it can rapidly be installed and working.

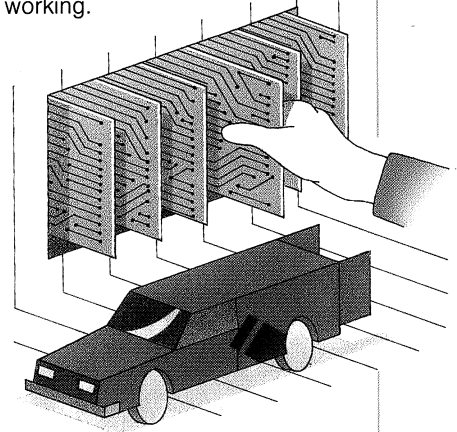

Research and resources

We have the largest research department in Europe, at Martlesham Heath. Three quarters of our budget was spent on the development of new systems. This covers everything from fibre optics to visual telephones. We have considerable experience in the whole field of micro-chip technology as well as a head start in all kinds of communications technology.



Behind Merlin – the strength of British Telecom

Merlin is the specialist organisation set up by British Telecom to develop and market advanced terminal equipment for businesses. It is backed by the full strength of British Telecom resources and expertise. Over the years, British Telecom has established itself as a leader in the field of telecommunications hardware and networks, and can

fairly claim to be the only Office Automation supplier that really understands the new

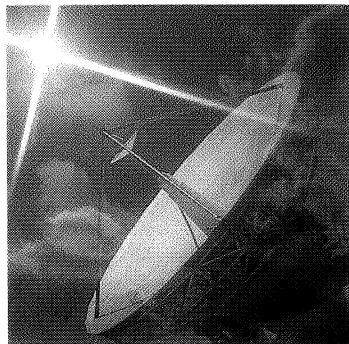

communications technologies.

We enjoy an enviable reputation as a sound, reliable supplier of communications equipment. We supply items which have been tested and proven in stringent market conditions. Reliability and ease of use are hallmarks of the Merlin range.

M2200 Series Business Computer

Hardware	M2215	M2226	M2235
Operating system	CP/M*	CP/M* MP/M*	MP/M*
Processor	8085 AH2	8085 AH2	8085 AH2
Memory capacity	64K	256K	256K
Data storage	Two 5¼in floppy disk drives. Uses double-sided quadruple density disks. (780Kb).	One 5¼in 5Mb Winchester hard disk drive and one 5¼in floppy disk drive. Uses double-sided quadruple density floppy disks. (780Kb).	One 5¼in 10Mb Winchester hard disk drive and one 5¼in floppy disk drive. Uses double-sided quadruple density floppy disks. (780Kb).
Disk drive/processor dimensions	width 510mm; depth 405mm; height 150mm		
Screen size	24 x 80 characters		
Screen colour	green phosphor		
VDU dimensions	width 410mm; depth 330mm; height 350mm		
VDU weight	13.6kg		
Keyboard type	detachable; QWERTY layout with numeric pad		
Keyboard dimensions	width 410mm; depth 220mm; height 65mm		
Keyboard weight	2.3kg		
Printer interface	Serial RS232C		
M2200 Software			
Standard software	Merlin Master, CP/M* m Basic	Merlin Master, CP/M,* MP/M,* m Basic	Merlin Master, MP/M* and m Basic
Modem			
Modes	Teletype and Viewdata		
Memory	auto-dial directory, programmed from terminal		
Log-on	automatic or manual		
Transmission speeds	1200/75 and 300/300 bits/sec		
Puma Teleprinter			
Memory	message store, programmed and accessed from remote terminal or Puma keyboard		
Transmission speed	Telex, 400 characters/min; to/from remote terminal, 1800 characters/min		
Other features	automatic re-dial when number engaged 'store and forward' message transmission 7 x 5 dot matrix printer, 69 column line width solid state QWERTY keyboard optional paper-tape attachment		

* A registered trademark of Digital Research Inc.

Merlin is British Telecom's specialist marketing organisation for advanced business terminal equipment.

If you would like further information on these or any other Merlin products, please dial 100 and ask for FREEFONE MERLIN. The operator will put you through to your nearest Merlin sales office, where our staff are ready to discuss your needs.

The products described in this brochure are available only from British Telecom Merlin.



Please note: we do our best to supply our customers with the products they ask for but we may have to provide products which do not accord exactly with the descriptions, illustrations and shades of colours shown in this leaflet.

APPROVED for use with telecommunication systems run by British Telecommunications in accordance with the conditions in the instructions for use.

T Merlin M1100

Communicating VDU Terminal

>Surely, by now, dialling and connecting up to the computer bureau should be automatic.<

>Why can't my terminal communicate with Viewdata and Electronic Mail as well as distant computers?<

>It's crazy to buy a terminal that can't be upgraded into a computer.<

Merlin
Systems Business Systems Business Systems Business Systems Business Systems Business

Merlin M1100

Computer dialling made simpler and quicker than ever



Electronic
Mail

Viewdata

Bureau
Services

Future
Services

With the Merlin M1100, a complete package is available for the first time as a single product from a single supplier. Its basic components are these:

The screen: Easy on the eye in every respect, the screen is angle adjustable and offers high definition for comfortable viewing.

The keyboard: Able to satisfy even the most professional typist, the keyboard makes short work of entering messages while the integrated numeric pad is useful for calculations and ideal for viewdata.

The modem: This is the heart of the M1100's capabilities. Like any other modem it links your terminal to a telephone line. It will store up to ten telephone numbers plus passwords and all the information you need to send in order to connect up. It will complete a connection automatically with just one stroke at the keyboard, and will provide the same access to non bureau services such as electronic mail and viewdata.

Printers: There is a choice of three printers, dot matrix *and* daisy wheel, to match every print-out need. Paper copies can be provided of any information passing in or out—viewdata graphics included.

Accessories: The M1100 comes with all the accessories you need to make best use of the system. These include a choice of print wheels and ribbons, continuous stationery, paper handling equipment and acoustic hoods.

The Merlin total back-up

A comprehensive service

When you invest in the M1100, you gain not only a superb piece of equipment but a full range of back-up services into the bargain. We can assist with finance and installation.

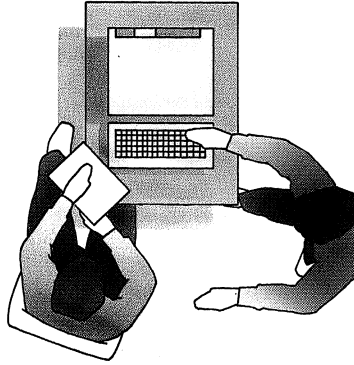
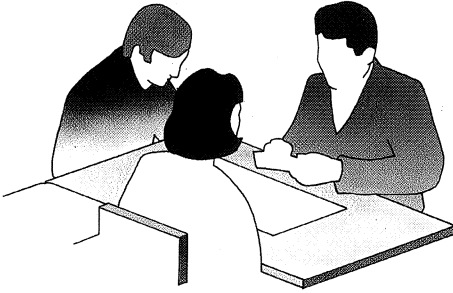

We take care to ensure that any new installation is running smoothly. Thereafter we offer the full resources of Merlin's engineering and maintenance division, a nationwide network fully equipped for efficient

after-sales back-up. As well as routine servicing, we provide rapid emergency response from the Merlin Maintenance Express Service and our own customer support personnel.

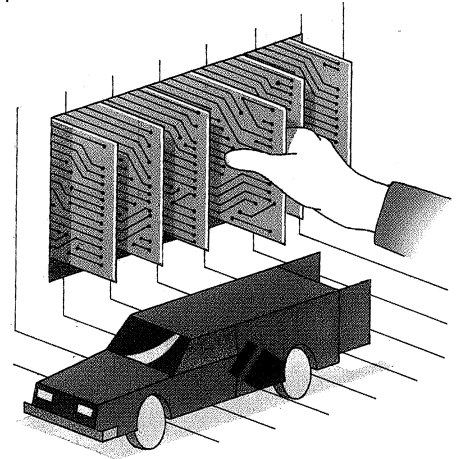

Behind Merlin – the strength of British Telecom

Merlin is the specialist organisation set up by British Telecom to develop and market advanced terminal equipment for businesses. It is backed by the full strength of British Telecom resources and expertise. Over the years, British Telecom has established itself as a leader in the field of telecommunications

hardware and networks, and can fairly claim to be the only Office Automation supplier that really understands the new communications technologies.



We enjoy an enviable reputation as a sound, reliable supplier of communications equipment. We supply items which have been tested and proven in stringent market conditions. Reliability and ease of use are hallmarks of the Merlin range.

and much, much more

other services. You can thus expand your options at no extra cost while reducing your investment in additional terminal equipment. Other services you can access include:

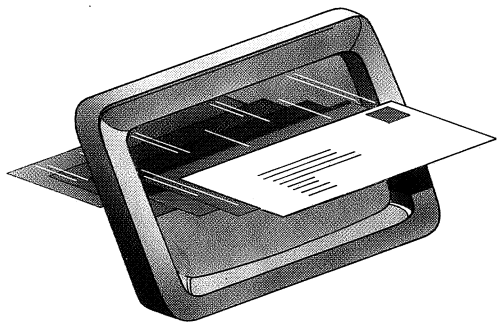

Electronic mail: This facility takes the hit and miss out of sending and receiving information. Safer and faster than the post, it transmits messages instantly to your correspondent's electronic 'in tray'. It avoids the delays of telephoning, with no need to wait for a clear line or to catch your contact at his desk.

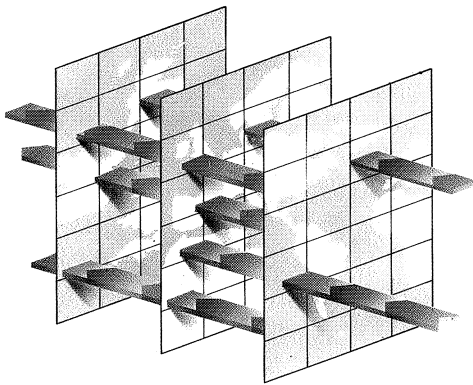

Linked to Telecom Gold the M1100 can also send messages via a gateway to the telex network. Telecom Gold from British Telecom is just one of several electronic mail services now available.

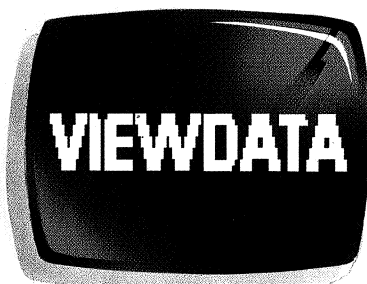

Viewdata: This service brings you thousands of pages of information from airline schedules to the latest City prices. Gateway facilities allow access to the databanks of large numbers of information providers, while electronic messaging in a variety of forms provides a versatile communicating tool. A number of viewdata services are currently available, the best known being Prestel from British Telecom.

Packet SwitchStream: If you subscribe to PSS or IPSS, the M1100 will give you access to that network. You can call up a computer anywhere in the world without having to worry about compatibility.

In-house computers: As well as linking you to remote bureaux, the M1100 can serve as a terminal for your own, in-house computer.

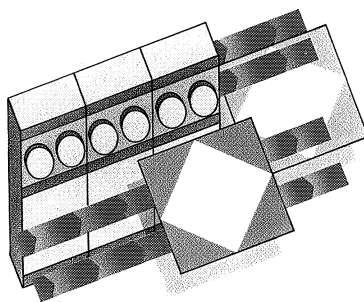

All these are bonuses. They mean that as well as dialling bureaux you can look up information on Prestel, send messages electronically, talk to other people's computers via SwitchStream and link up to your own computer—all from one compact terminal. Savings in space, time and convenience are considerable. Cost efficiency is assured.

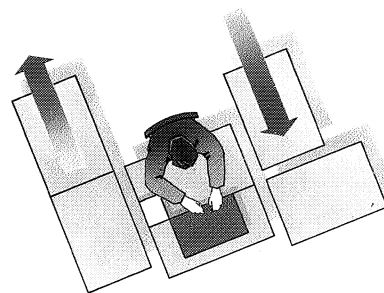

Upgradability

The M1100 is one of the first in a carefully matched family of specialised business machines designed to provide telecommunications and computing in one, integrated system. Add a disk drive and processor unit and your M1100 becomes a microcomputer with a new set of capabilities alongside the old. At Merlin we believe in adaptability built in from the start, in systems that will grow in step with the needs of your business. So if you later develop an in-house computer system or expand into additional services, your initial investment is secure. Furthermore, we will be on hand to supply all the software and associated documentation that future developments may require.

The terminal that stores, dials, re-dials,



Time sharing computer bureaux have played a key role in data information processing over the last decade or so, principally by allowing organisations without their own computers to enjoy the benefits of advanced computing power.

But there has always been one major problem.

Until now bureau dialling and logging on has been a complicated business. There is the need to remember or look up lengthy numbers and log-on sequences whenever you make a call. It then takes time to key them in. Mistakes are easy, which means more time wasted as you start again. Every hold-up along the way wears down the operator's willingness to use the service—and that, of course, diminishes the cost-efficiency of the system, particularly if the terminal in question has no other function.

The Merlin M1100 cuts through every one of those problems to offer truly cost-effective bureau dialling for the first time ever. Its remarkable range of features includes:

- Automatic dialling and log-on
- A non-volatile memory that the user himself can programme
- Access to other services besides computer bureaux
- Straightforward operating procedures.

It adds up to trouble-free bureau dialling, and the chance, additionally, to claim the same terminal for other uses. All that at less cost than many suppliers charge for a conventional, single-function system.

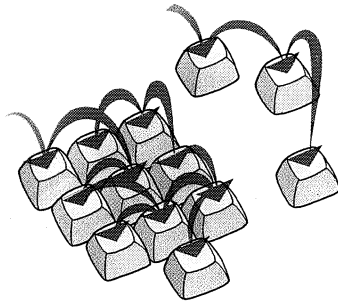

Automatic dialling and connection

The modem memory contains ten slots, allowing you to store details of ten different services. Each slot will hold the service name, its telephone number, the technical criteria that govern the transmission, and the required connection (log-on) sequence including your password.

When you instruct it, the modem will dial and receive automatically, so cutting out the effort—and frequent exasperation—of having to dial manually. It saves mistakes, saves valuable time, and avoids having to remember complicated sequences.

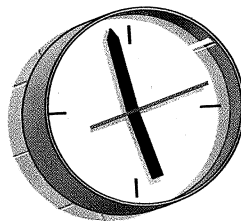

For still greater convenience the modem can repeat a number until it gains access.

Moreover, you are not restricted to the ten services stored in the memory. The modem will allow conventional dialling to other services, and in any procedure you can take over manually if you prefer.

Simpler user programming

The user himself can programme the memory by following a simple set of instructions in plain English. And if needs change—or if bureaux themselves require modifications to log-on sequences—the program can be altered accordingly without having to call in a specialist engineer.

An instruction menu will also be displayed, making it possible for untrained or very occasional users to progress straight to keying in commands.

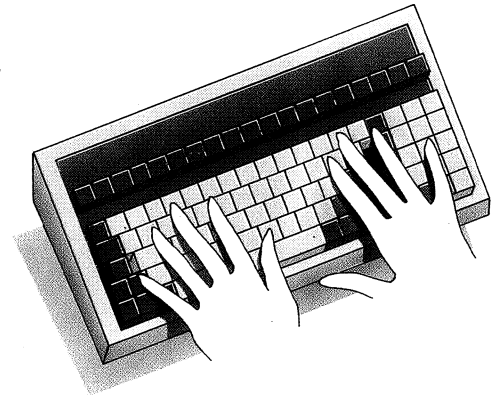

Display of service options

When you switch on, the screen displays a handy directory of the services stored in the memory. There is no need therefore to remember names and details.

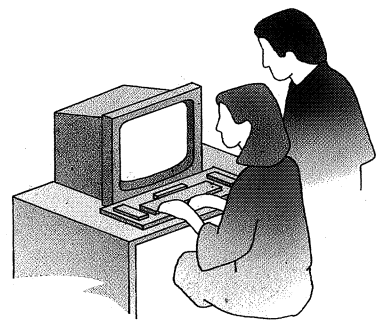

Multiple service access

Linking you to a bureau service, the M1100 performs the full functions of a remote computer terminal using the storage and processing power of the service in question. But the same terminal also links you to a range of

M1100

Hardware	
Transmission modes	normal and viewdata
Modem memory	auto-dial directory, programmed from keyboard
Log-on	automatic, semi-automatic, by function key, or manual, from a keyboard
Transmission speeds	1200/75 and 300/300
Screen size	24 x 80 characters
Screen colour	green phosphor
VDU dimensions	width 410mm; depth 330mm; height 350mm
VDU weight	13.6kg
Keyboard type	detachable; QWERTY layout, with numeric pad
Keyboard dimensions	width 410mm; depth 220mm; height 65mm
Keyboard weight	2.3kg
Printer interface	Serial RS232C

Merlin is British Telecom's specialist marketing organisation for advanced business terminal equipment.

If you would like further information on these or any other Merlin products, please dial 100 and ask for FREEFONE MERLIN. The operator will put you through to your nearest Merlin sales office, where our staff are ready to discuss your needs.

The products described in this brochure are available only from British Telecom Merlin.



Merlin

British Telecom Business Systems

Please note: we do our best to supply our customers with the apparatus they ask for but we may have to provide apparatus which does not accord exactly with the descriptions, illustrations and shades of colours shown in this leaflet.

APPROVED for use
with telecommunication systems
run by British Telecommunications
in accordance with the conditions
in the instructions for use.

Merlin is British Telecom's specialist marketing organisation for advanced business terminal equipment.

If you would like further information on these or any other Merlin products, please dial 100 and ask for FREEFONE MERLIN. The operator will put you through to your nearest Merlin sales office, where our staff are ready to discuss your needs.

The products described in this brochure are available only from British Telecom Merlin.

Please note: we do our best to supply our customers with the apparatus they ask for but we may have to provide apparatus which does not accord exactly with the descriptions, illustrations and shades of colours shown in this leaflet.



Merlin

British Telecom Business Systems

Merlin is British Telecom's specialist marketing organisation for advanced business terminal equipment.

If you would like further information on these or any other Merlin products, please dial 100 and ask for FREEFONE MERLIN. The operator will put you through to your nearest Merlin sales office, where our staff are ready to discuss your needs.

The products described in this brochure are available only from British Telecom Merlin.

Please note: we do our best to supply our customers with the apparatus they ask for but we may have to provide apparatus which does not accord exactly with the descriptions, illustrations and shades of colours shown in this leaflet.



Merlin

British Telecom Business Systems

Merlin is British Telecom's specialist marketing organisation for advanced business terminal equipment.

If you would like further information on these or any other Merlin products, please dial 100 and ask for FREEFONE MERLIN. The operator will put you through to your nearest Merlin sales office, where our staff are ready to discuss your needs.

The products described in this brochure are available only from British Telecom Merlin.

Please note: we do our best to supply our customers with the apparatus they ask for but we may have to provide apparatus which does not accord exactly with the descriptions, illustrations and shades of colours shown in this leaflet.



Merlin

British Telecom Business Systems

Merlin is British Telecom's specialist marketing organisation for advanced business terminal equipment.

If you would like further information on these or any other Merlin products, please dial 100 and ask for FREEFONE MERLIN. The operator will put you through to your nearest Merlin sales office, where our staff are ready to discuss your needs.

The products described in this brochure are available only from British Telecom Merlin.

Please note: we do our best to supply our customers with the apparatus they ask for but we may have to provide apparatus which does not accord exactly with the descriptions, illustrations and shades of colours shown in this leaflet.



Merlin

British Telecom Business Systems

Daisywheels

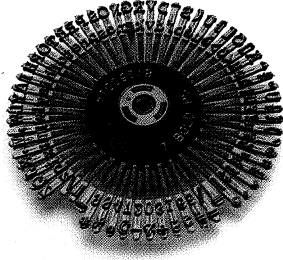

Daisywheels for the daisywheel printer.

Thirteen interchangeable 'one touch' printwheels give a choice of

thirteen typefaces, 124 characters each. Long life double-mould design, with positive location clips.

Courier 10

Order 985054

This is what the text will look like when you use this print wheel. This is the full range of characters available: ABCDE FGHIJKLMNOPQRSTUVWXYZabcdefghijklmnopqrstuvwxyz0123456789:;@ !"#%&'()*+,-./[\]^_`<=>?{|}~`àç£µ°´™®©¼½¾¶éùè¨f\$¥ÄÖÜç_äöüß

Cubic Proportional Space

Order 985055

This is what the text will look like when you use this print wheel. This is the full range of characters available: ABCDE FGHIJKLMNOPQRSTUVWXYZabcdefghijklmnopqrstuvwxyz0123456789:;@ !"#%&'()*+,-./[\]^_`<=>?{|}~`àç£µ°´™®©¼½¾¶éùè¨f\$¥ÄÖÜç_äöüß

Tile Italic 10/12

Order 985056

This is what the text will look like when you use this print wheel. This is the full range of characters available: ABCDE FGHIJKLMNOPQRSTUVWXYZabcdefghijklmnopqrstuvwxyz0123456789:;@ !"#%&'()*+,-./[\]^_`<=>?{|}~`àç£µ°´™®©¼½¾¶éùè¨f\$¥ÄÖÜç_äöüß

Madeline Proportional Space

Order 985057

This is what the text will look like when you use this print wheel. This is the full range of characters available: ABCDE FGHIJKLMNOPQRSTUVWXYZabcdefghijklmnopqrstuvwxyz0123456789:;@ !"#%&'()*+,-./[\]^_`<=>?{|}~`àç£µ°´™®©¼½¾¶éùè¨f\$¥ÄÖÜç_äöüß

Prestige Elite

Order 985058

This is what the text will look like when you use this print wheel. This is the full range of characters available: ABCDE FGHIJKLMNOPQRSTUVWXYZabcdefghijklmnopqrstuvwxyz0123456789:;@ !"#%&'()*+,-./[\]^_`<=>?{|}~`àç£µ°´™®©¼½¾¶éùè¨f\$¥ÄÖÜç_äöüß



Scan Courier10

Order 985059

This is what the text will look like when you use this print wheel. This is the full range of characters available: ABCDEFGHIJKLMNOPQRSTUVWXYZabcdefghijklmnopqrstuvwxyz0123456789:;@!"#\$%&'()*+,-./<=>?É\^_ÑÀ†Ø~æçâ°'|™Æ`¼¼¼¼øÇñ"f\$ÿÄÖÜ;_äöüß

A/N Scientific10

Order 985060

This is what the text will look like when you use this print wheel. This is the full range of characters available: ABCDEFGHIJKLMNOPQRSTUVWXYZabcdefghijklmnopqrstuvwxyz0123456789:;α!⁹/ω%∞∏()*+,-'/¹\⁷[-_]<=>?{~λ+πρς⁵ξ³⁶∫⁴²⁸|β∫γ⁰ατσθΔΩη]εδμ+

OCR-B

Order 985061

This is what the text will look like when you use this print wheel. This is the full range of characters available: ABCDEFGHIJKLMNOPQRSTUVWXYZabcdefghijklmnopqrstuvwxyz0123456789:;@!"#\$%&'()*+,-./[\]^_`<=>?{|}~àç&µ°'†™©¼¼¼¼øÇñ"f\$ÿÄÖÜ;_äöüß

Letter Gothic12

Order 985062

This is what the text will look like when you use this print wheel. This is the full range of characters available: ABCDEFGHIJKLMNOPQRSTUVWXYZabcdefghijklmnopqrstuvwxyz0123456789:;@!"#\$%&'()*+,-./[\]^_`<=>?{|}~àç&µ°'†™©¼¼¼¼øÇñ"f\$ÿÄÖÜ;_äöüß

Scan P Elite12

Order 985063

This is what the text will look like when you use this print wheel. This is the full range of characters available: ABCDEFGHIJKLMNOPQRSTUVWXYZabcdefghijklmnopqrstuvwxyz0123456789:;@!"#\$%&'()*+,-./É\^_Ñ<=>?À†Ø~æç&â°'|™Æ`¼¼¼¼øÇñ"f\$ÿÄÖÜ;_äöüß

Scientific 12

Order 985064

δ⁹⁴β₊αη(Π*+,-;/#>↳~{α+†.≈:±<∇, µ⁸ÅΘΨ/x∫T)~≅Φ{""(±)†}÷[°^}~`=]+χΔ_⁰∫θψκ=⇒±∞≡Φ&||≤∂≠⊥≥∂∞•{γ²⁶ω/ρπ∞Λτ⁵ΞΓ³Ω¹|ιεο][ξλ[}Σ_ζσ⁷

Cubic15

Order 985065

This is what the text will look like when you use this print wheel. This is the full range of characters available: ABCDEFGHIJKLMNOPQRSTUVWXYZabcdefghijklmnopqrstuvwxyz0123456789:;@!"#\$%&'()*+,-./[\]^_`<=>?{|}~àç&µ°'†™©¼¼¼¼øÇñ"f\$ÿÄÖÜ;_äöüß

Bold Proportional Space

Order 985066

This is what the text will look like when you use this print wheel. This is the full range of characters available: ABCDEFGHIJKLMNOPQRSTUVWXYZabcdefghijklmnopqrstuvwxyz0123456789:;@!"#\$%&'()*+,-./[\]^_`<=>?{|}~àç&µ°'†™©¼¼¼¼øÇñ"f\$ÿÄÖÜ;_äöüß

Tile Narrator10

Order 985103

THIS IS WHAT THE TEXT WILL LOOK LIKE WHEN YOU USE THIS PRINT WHEEL. THIS IS THE FULL RANGE OF CHARACTERS AVAILABLE: ABCDEFGHIJKLMNOPQRSTUVWXYZABCDEFGHIJKLMN OPQRSTUVWXYZ0123456789:;@!"#\$%&'()*+,-./[\]^_`<=>?{|}~ÀÇ&µ°'†™©¼¼¼¼øÇñ"f\$ÿÄÖÜ;_ÄÖÜß

Merlin is British Telecom's specialist marketing organisation for advanced business terminal equipment. If you would like further information on these or any other Merlin products, please dial 100 and ask for FREEFONE MERLIN. The operator will put you through to your nearest Merlin sales office, where our staff are ready to discuss your needs. The products described in this brochure are available only from British Telecom Merlin.

Please note: we do our best to supply our customers with the apparatus they ask for but we may have to provide apparatus which does not accord exactly with the descriptions, illustrations and shades of colours shown in leaflet.



>WordStar*< software programs

Word processor quality. Micro economy.

This tells you what the document you're dealing with is and exactly where you are (in this case, we're on page 1, line 1, character 39).

This allows you to move around within the typing on display, either character to character or word to word.

This is also a cursor movement but, in this case, from line to line or paragraph to paragraph.



This is your key to a whole list of useful features such as automatic paragraph reformatting, tab set and various others. The letters in front of each function simply refer to the letters on your keyboard.

These commands take you on to other major functions such as PRINT. Also in this section is the friendly HELP which will, in turn, guide you to the three different complexities of 'menu'.

An invaluable editing aid for corrections to small or large sections of text.

As more and more businesses become aware of the advantages of word processing, they also come to realise that, in many cases, the cost of starting a system can be as daunting as the thought of coping with it.

Now, with WordStar*, both these problems are solved.

Everything you want.

WordStar* has been called 'the ultimate word processor' by one expert and has certainly come to be accepted by the industry as the standard by which other word processing software packages are judged.

What it does, with the special Merlin WordStar* pre-programmed function keys is to give your

M2200 all the capabilities of a word processor but at a fraction of the cost.

Type fresh text, for instance, and it'll make the line breaks for you, move automatically from page to page, even numbering the pages as it goes.

Even if you want to change or insert a word or add a complete new section, it'll shuffle the text to cater for it.

In other words, once text has been fed into the system, you'll never have to retype it.

And more.

WordStar* also offers many additional features such as horizontal text scrolling for extra wide stationery, plus various print enhancements such as under-scoring, bold face, subscript, superscript and overprint.

Economy of scale.

With the ever rising cost of office space, one of the key considerations in choosing a word processor must be the sheer amount of space that it takes up. Because WordStar* is simply making use of your M2200, it saves you the extra space that would be taken up by a separate word processor.

Merlin
Business Systems

WordStar*

Economy of effort.

Although it's a very sophisticated package, WordStar* is designed for the non-specialist user. Every command you need to know is presented on your screen in menu form and cleared when you need to move on.

And, because the menu can be presented at three levels of complexity, it allows you to become familiar with the system at whichever speed you choose.

Of course, there are available for those who need them, special Merlin training courses. And, in addition, our trained staff are always available to answer your queries.

Economy. Full stop.

So far, so good.

But at this stage, you're going to have to sit down and ask yourself how much it's all going to cost.

The answer is simple.

Examine the difference between purchasing a conventional word processor and adding the WordStar* package to your M2200 and you'll find that it is very significant indeed.

And if you were to opt for a multi-user system, the economy could be even greater.

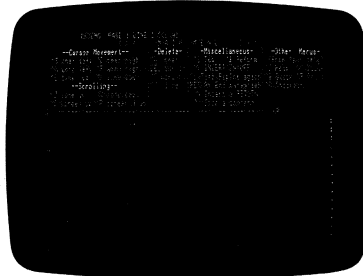

This is the most comprehensive menu and has been designed for those who want to start slowly and feel their way carefully through the WordStar* program.

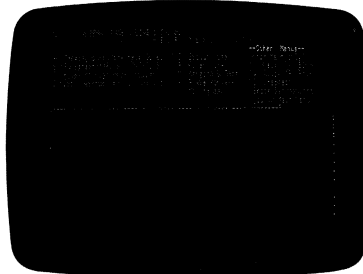

This display shows on screen for a short time only and you'll be able to use it when you're a little more familiar with WordStar*.

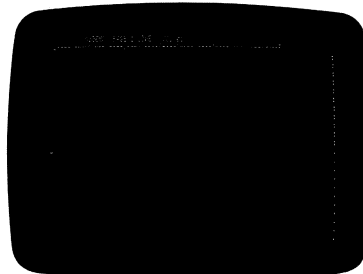

This display is for the most experienced user.

High gloss communications.

Once you've added the WordStar* packages to your M2200, you can generate perfectly finished business documents and letters based on the information which is stored by your other Merlin software packages. But, in addition to this, there are packages which can make WordStar* itself even more effective.

The personal touch.

MailMerge*, for instance, is a file-merging program which can be used to personalise a WordStar* prepared letter.

It is ideal for multiple mailing exercises, it'll supply WordStar* with the name, address and any other personal details for every single personalised version of a standardised letter.

And it does all this directly, with no tedious intermediate paperwork.

No more spelling mistakes.

SpellStar* is another godsend. What it does is to proof-read a document and allow mistakes to be corrected using WordStar*. On SpellStar's* standard dictionary, there are 20,000 words. If you want to add more, you can.

* A MicroPro International Corp product.

Merlin is British Telecom's specialist marketing organisation for advanced business terminal equipment.

If you would like further information on these or any other Merlin products, please dial 100 and ask for FREEFONE MERLIN. The operator will put you through to your nearest Merlin sales office, where our staff are ready to discuss your needs.

Whilst we do our best to supply customers with the products they want, we reserve the right to provide products which do not accord exactly with the descriptions and illustrations appearing in this leaflet.

 **Merlin**
British Telecom Business Systems

>InfoStar*< software programs

The fast and efficient way through the information maze.

This simply tells you whether you're adding data to a file, creating a new form, or simply enquiring.

This is the means you use to move around the form. Maybe, for example, you want to move from 'employee name' to 'department'.

This enables you to include a standard piece of information throughout an entire file.

This tells you which form you're working on.

This is an example of input variation. If, for instance, you were to set up 'pension status' as, say, 'married man' or 'single woman' on the Master File, this status would automatically be checked as new data was entered.

One of InfoStar's* most important features is that, whilst checking information against another file, it is also possible to introduce a new piece of data. Maybe, for instance, our 'married man' would pay a different contribution to the Sports and Social Club than the 'single woman'.

For any individual or company, a large uncontrollable volume of data can be like a millstone around the neck.

Properly handled, however, it can make a job more satisfying and enjoyable as well as leading to much greater efficiency.

Twenty filing cabinets on your desktop.

Before the advent of micro-computers, you might have made use of card index or filing systems.

In its own way, this was an efficient way of managing information.

Unfortunately, it consumed inordinate amounts of expensive space and executive time.

InfoStar* achieves exactly the same as a manual system. But in a fraction of the time and using only the space which your M2200

microcomputer takes up on your desktop.

Just to give an example: InfoStar* can sort through a file at speeds of up to 560 records a minute until it finds the relevant data.

What goes into InfoStar*?

The InfoStar* Data Base Management System combines the power of two already well-known software packages.

DataStar* is a high powered data entry and retrieval program.

ReportStar* is a versatile program which can sort, update and report data in countless different ways.

Now, by bringing together these two programs, InfoStar* gives you one of the most powerful and versatile ever desktop management tools.

Creating time where none before existed.

If your business deals in or relies on a constant flow of information, you stand to benefit greatly from InfoStar*.

In fact, InfoStar* can be used by virtually any business for virtually any business task.

Advertising budgets and schedules, for instance. Desktop market or consumer research. The sorting out of postal codes for mailings. The accurate extraction of particular sets of customers from general listings. Parts and inventory updates.

Even accountants or financial departments can use InfoStar* for accounting systems such as asset registers.

InfoStar* can be used to keep track of just about anything. From mailing and membership lists to customer accounts and sales appointments.

Merlin
Systems Business Systems Business Systems Business Systems Business Systems Business Systems Business

InfoStar*

Making InfoStar* part of your business means creating extra time. And no business needs reminding how valuable that can be.

InfoStar* is fast, InfoStar* suits your style.

InfoStar* will manage your data quickly, accurately and easily.

But, above all, it allows **you** to call the tune.

Because you can enter the data, and sort and manipulate it any way you want. You can even generate reports in whichever format you decide upon.

In other words, whatever style you choose, whatever rules you set, InfoStar* will make it work.

Retrieval, for instance. InfoStar* will uncover the information you want. Even if you can only recall a fraction of it. For instance, if you're searching for surnames beginning

with 'W' in the Greater Manchester area, InfoStar* can deliver.

InfoStar*'s Quick Report Generator will, naturally, print you a copy of any 'card' you ask for. Inside 60 seconds to be precise.

No mistakes, no disasters.

With InfoStar*, it's nearly impossible to key in a mistake because every entry you make is cross-checked according to verification routines which you define. And even if you make a keyboard error, you can be sure that it'll never lead to the disaster of accidentally erased files.

No previous experience required.

Like all Merlin software, InfoStar* is designed for those who have never learnt programming language. Easy-to-understand 'menus' give you every possible option in plain, simple English and then lead you on to your next step.

And 'help' screens are readily available, simply by pressing a key.

And finally, you can get it all down on paper.

Combine all this with your WordStar* word processing program and you've got everything you need to draw up perfectly typed documents based on your InfoStar* records.

A multiple personalised mailing, for instance. Address labels or staff records. Membership lists or customer/sales update reports.

The possibilities are endless. In fact, with InfoStar* the world of information is your oyster.

*A MicroPro International Corp product.

Merlin is British Telecom's specialist marketing organisation for advanced business terminal equipment.

If you would like further information on these or any other Merlin products, please dial 100 and ask for FREEFONE MERLIN. The operator will put you through to your nearest Merlin sales office, where our staff are ready to discuss your needs.

Whilst we do our best to supply customers with the products they want, we reserve the right to provide products which do not accord exactly with the descriptions and illustrations appearing in this leaflet.



Merlin

British Telecom Business Systems

Business Desk*

Always ready for change.

As well as flexibility in terms of application, Business Desk* is also able to change with the business it serves.

For instance, having been tailored to suit the initial requirement of a user, it can then be reconfigured as those requirements change.

It can grow with your business either into a multi-user system or by increased data storage. Or both.

Naturally, the development of Business Desk* never stands still. But you can be sure that any enhancement or additions we make will be compatible.

'How's business today?'

As a business grows, it can often become too wrapped up in everyday detail to be able to take a daily or weekly look at crucial cash or stock situations.

Business Desk* will, on demand, report on the many aspects of your company's financial status such as stock and bank account, customer turnover and statements as well as aged debtors.

It'll also provide an up-to-the minute VAT report and analysis.

Business Desk* speaks your language.

As you can see from our sample display, Business Desk* has been designed specifically for anyone who needs the capabilities of a computer, not just for computer experts.

Despite its sophisticated features, it has a simplicity and ease of operation that stems from its easy to follow 'menus' and standardised screen displays.

So the user quickly learns what Business Desk* requires and, indeed, what a great deal it has to offer.

* A Paxton Computers Ltd product.

Merlin is British Telecom's specialist marketing organisation for advanced business terminal equipment.

If you would like further information on these or any other Merlin products, please dial 100 and ask for FREEFONE MERLIN. The operator will put you through to your nearest Merlin sales office, where our staff are ready to discuss your needs.

Whilst we do our best to supply customers with the products they want, we reserve the right to provide products which do not accord exactly with the descriptions and illustrations appearing in this leaflet.

 **Merlin**
British Telecom Business Systems

Sales Desk*

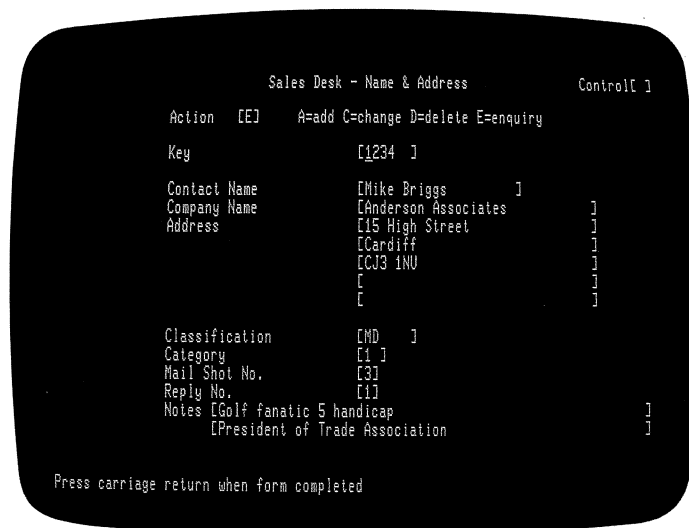

Making the right kind of contact.

These days presentation is one of the most important ingredients in setting up a sale. And Sales Desk*, in conjunction with WordStar**, can address a perfectly typed letter to some or all of your prospects, or to any selection or classification you choose (all managing directors of oil companies with less than 100 employees, for instance. Or anyone who has a wedding anniversary that week!).

Letters can be informal or formal, even addressed to a title (such as Production Director) in the absence of an individual's name.

Sales Desk*, correctly used, can mean 100% accuracy. And coupled with WordStar, it can help to improve dramatically response to your sales drives.

How to get a perfect report.

For a sales team, up-to-date and accurate reports and listings are crucial.

You could, for instance, ask Sales Desk* to list all businesses of a particular type in a given area.

And once you've fed your sales reporting procedures into Sales Desk*, you can use it as a diary to remind you, say, when to call back a prospect.

The system that grows as fast as your sales.

As your company grows or changes, Sales Desk* will allow the files to grow or change (a 5¼" floppy disk can hold up to 2000 sales records).

Groups of entries can also be moved between disks to improve access to information. Which means that you'll never have the problem of a dramatic growth in sales outstripping the capacity of the system.

Sales Desk* talks plain English.

When you or your team are discussing a project with a prospective customer, you communicate in normal English. So does Sales Desk*.

Because it's operated through easily understood screen 'menus' it's highly accessible to anyone who wants to use it.

* A Paxton Computers Ltd product.

** A MicroPro International Corp product.

Merlin is British Telecom's specialist marketing organisation for advanced business terminal equipment.

If you would like further information on these or any other Merlin products, please dial 100 and ask for FREEFONE MERLIN. The operator will put you through to your nearest Merlin sales office, where our staff are ready to discuss your needs.

Whilst we do our best to supply customers with the products they want, we reserve the right to provide products which do not accord exactly with the descriptions and illustrations appearing in this leaflet.



dBase2*

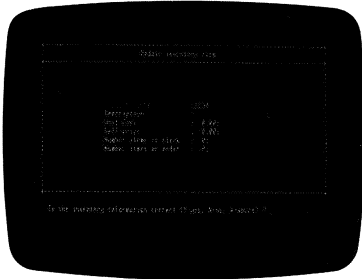

This is where the actual process of adding or changing information starts. But first, dBase 2* checks to see that the information isn't already on file. With conventional programs it can be very difficult to avoid this unnecessary and time consuming duplication.

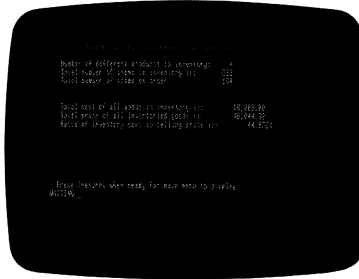

dBase 2* provides regular and accurate reporting, ideal for either operational or management reports. This display gives an up-to-the-minute indication on various aspects of items held in stock.

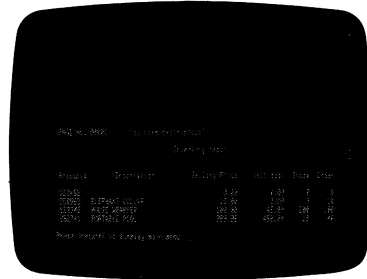

Now, going into more detail, we look at the stock situation on these products. This also shows all the related information such as the price of the goods in stock and the ratio of cost to selling price.

Ask dBase2* real business questions.

Thanks to its mainframe computer pedigree, dBase 2* is the most powerful information handling system available for your micro-computer.

And one to which you can put the toughest business questions.

To take an example: ask it how many of Product X there are on order, it gives you a straightforward answer. But then go on: how many of them will need wrappers? When are they due for delivery? What exactly is the value of orders outstanding?

And so on. Until all the possibilities are exhausted.

Having asked dBase 2* these questions and having received a precise and well ordered set of answers, you're then left free to consider the more global business implications.

Now data is a major business asset.

With dBase 2*, you have a full business information system that carries out your wishes quickly and accurately, and, most important, a system that can grow at the same rate as your company.

Data is constantly at hand. And because dBase 2* uses simple English, it's totally understandable.

And flexible too.

dBase 2* allows you to add, delete, edit, display, print and manipulate your information.

It lets you use one or more of your files for a whole variety of tasks.

And it allows untrained staff to run the most complex calculations.

Most important, it leaves your data and your programs independent of each other. So you can change one without changing the other.

For your business, dBase 2* could become more than a flexible information resource.

It could become an invaluable ally.

* An Ashton-Tate product.

Merlin is British Telecom's specialist marketing organisation for advanced business terminal equipment.

If you would like further information on these or any other Merlin products, please dial 100 and ask for FREEFONE MERLIN. The operator will put you through to your nearest Merlin sales office, where our staff are ready to discuss your needs.

Whilst we do our best to supply customers with the products they want, we reserve the right to provide products which do not accord exactly with the descriptions and illustrations appearing in this leaflet.

 **Merlin**
British Telecom Business Systems